



MODEL CMS

COMPACT MOTION SWITCH
ECONOMY MODEL WITH ONE SIGNAL SET POINT

WHAT IT IS, AND WHAT IT DOES

The Model CMS Motion Sensing Control is a compact unit designed to include all mechanical and electronic components in one housing. It will produce an output signal at a predetermined speed which may be either underspeed or overspeed. Rugged, heavy duty construction combined with solid state electronics and photo-electric technology, make this one of the most advanced detectors available.

The Model CMS protects all valuable rotating equipment including belt conveyors, bucket elevators, rotary feeders, or screw conveyors. It operates in either a clockwise or counterclockwise direction and mounts in any position.

MODEL CMS MOTION SPEED CONTROL

MODEL	DESCRIPTION	SHPG. WT. LBS.
CMS-1G	120 VAC General Purpose, NEMA 4, 4X	6
CMS-1X	120 VAC Explosion proof, NEMA 7/9	6
CMS-2G	240 VAC General Purpose, NEMA 4, 4X	6
CMS-2X	240 VAC Explosion proof, NEMA 7/9	6
CMS-3G	24V AC/DC General Purpose, NEMA 4, 4X	6
CMS-3X	24V AC/DC Explosion proof, NEMA 7/9	6

Epoxy coating option: add "E" to end of model number.

Dual Setpoint & Pulse Output Models available. Add "-DSPO" to end of model number.



OPERATION

1. The Model CMS senses motion by means of a precision metal disc mounted on the input shaft. This disc generates measurable light pulses as a series of slots on its periphery rotate past an infra-red light source. A photo-electric sensor monitors the series of light pulses and converts them to a digital electronic signal. Solid state circuitry then analyzes the digital signal and activates or deactivates the output relay at the pre-set signal speed. The Model CMS has an adjustable built-in time delay eliminating the need for a separate start-up time delay relay.
2. The Model CMS will sense underspeed or overspeed conditions. Three signal speed ranges are available with each unit. The low signal speed range is from 0.1 to 10 RPM. The medium signal speed range is 1 to 100 RPM, and the high speed range is 10 to 1000 RPM.
3. Field adjustment of the signal set point is easily accomplished by means of an adjustment screw. The signal speed ranges are selected by a three position toggle switch on the printed circuit board. For **UNDERSPEED** sensing, the signal point is set below the normal operating speed of the unit. The output relay will then de-energize if the speed drops below the signal set point. For **OVERSPEED** sensing the signal set point is set above the normal operating speed. The output relay will energize if the speed exceeds the signal set point. The output relay can be wired either normally open or normally closed.
4. Zero speed sensing can be accomplished by locking the signal set point adjustment screw at its lowest setting of 0.1 RPM. The output relay will then de-energize when the shaft speed of the unit approaches zero.

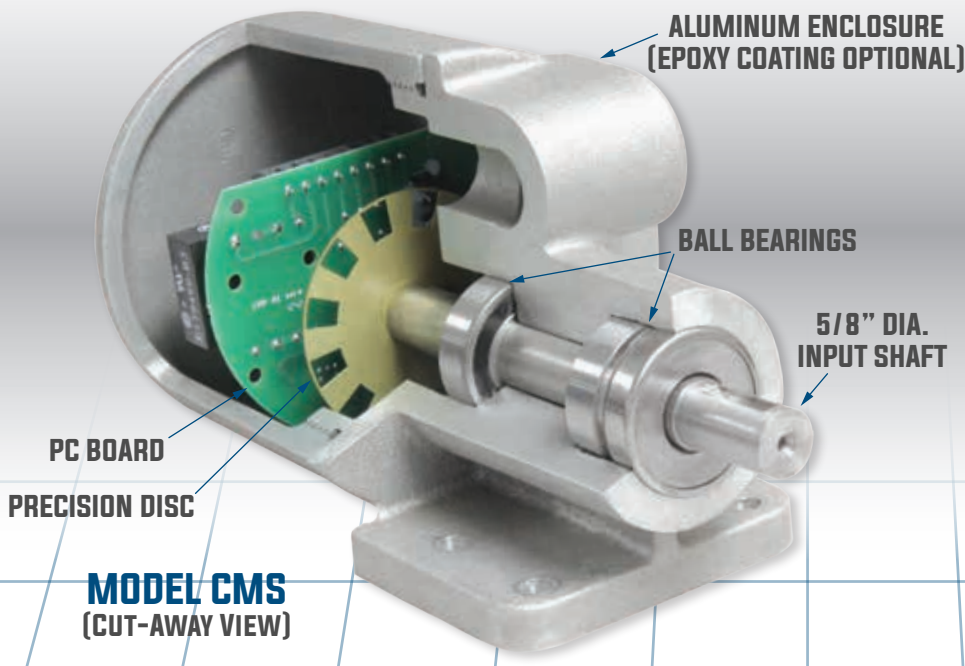

WIRING

The output of the Model CMS is a DP/DT relay connected to the terminal block at the rear of the unit. There are two sets of output contacts. Each set includes normally open, normally closed, and common. As a result, the unit can be used to control two separate circuits such as a motor starter and a signal light. Input power is connected from the source to contacts L₁ and L₂. A ground connection is also furnished.

MECHANICAL SPECIFICATIONS

RADIAL LOAD ON INPUT SHAFT: 125 lb. max.
END THRUST ON INPUT SHAFT: 100 lb. max.
ROTATION: Either clockwise or counterclockwise
DRIVING TORQUE: 1 inch-pound maximum
SHAFT: 5/8" diameter with 3/16" x 1" square key
ENCLOSURE: Aluminum with screw on cover. Optional epoxy coating available.
MEETS: NEMA Type 3S, 4, 4X; or NEMA Type 7: Class I, Groups C & D; NEMA Type 9: Class II, Groups F & G
BEARINGS: (2) Ball Bearings, permanently lubricated and sealed for life
SHAFT SEAL: Leather type oil seal
WEIGHT: 6 lb.
SIZE: 5" high x 5" wide x 8½" long

ELECTRICAL SPECIFICATIONS

INPUT VOLTAGE: 105-135 A.C., 50/60 Hz.
 210-250 volts A.C., 50/60 Hz. (Special Order)
OUTPUT: DPDT relay 3 Amp. Resistive at 120 volts A.C.
 DPDT relay 3 Amp. Resistive at 240 volts A.C.
 DPDT relay 3 Amp. Resistive at 30 volts D.C.
 1/10 Horse Power at 120 volts A.C.
 1/10 Horse Power at 240 volts A.C.
AMBIENT TEMPERATURE: 14°F to 131°F (-10°C to 55°C)
MAX. OPERATING TEMPERATURE: T6: 185°F (85°C) "X" units only
REPEATABILITY: +2% max. at constant voltage and temperature
POWER CONSUMPTION: 3 Watts maximum
SPEED RANGES: 3 Signal Speed Ranges
 LOW: 0.1 to 10 RPM
 MEDIUM: 1 to 100 RPM
 HIGH: 10 to 1000 RPM
SIGNAL POINT: Speed at which relay will de-energize for Underspeed, or energize for Overspeed. Recommended to be 15-20% lower than running speed. This will eliminate nuisance shutdowns.
START UP DELAY: Adjustable up to 45 seconds

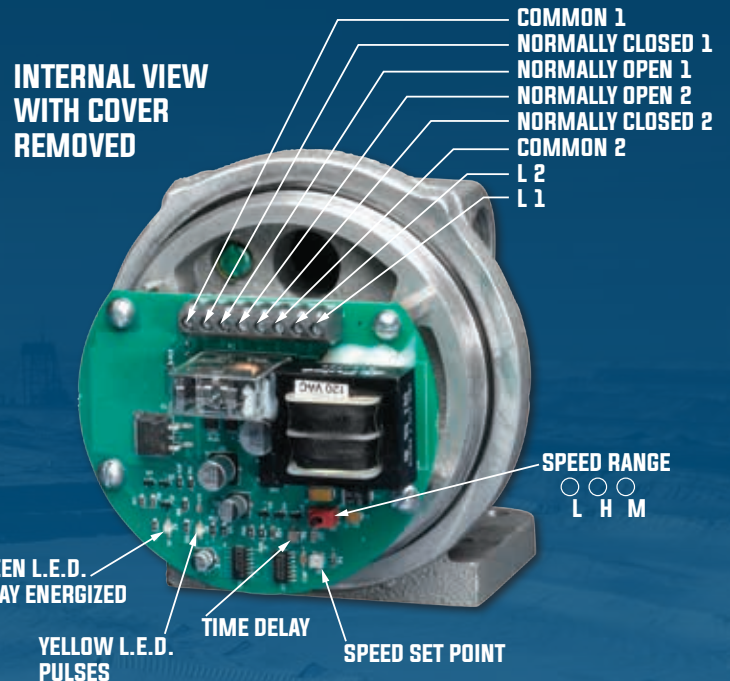

DIMENSIONS

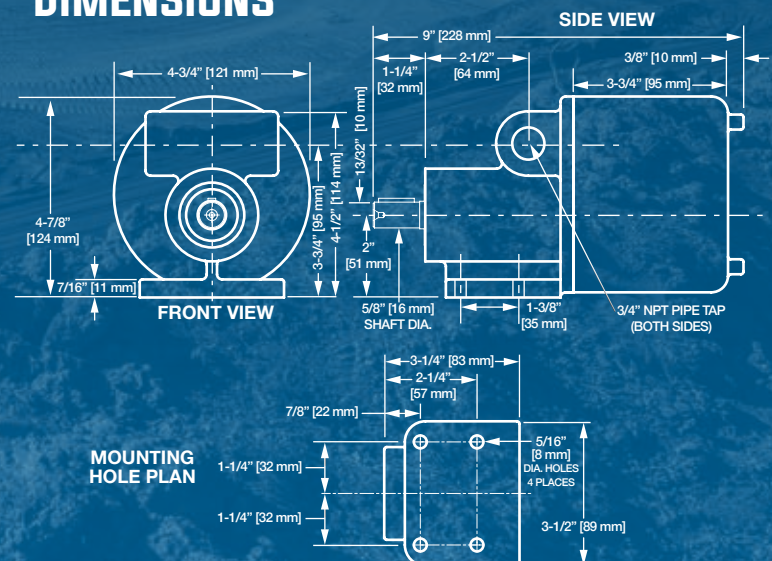

MODEL CMS TECHNICAL INFORMATION

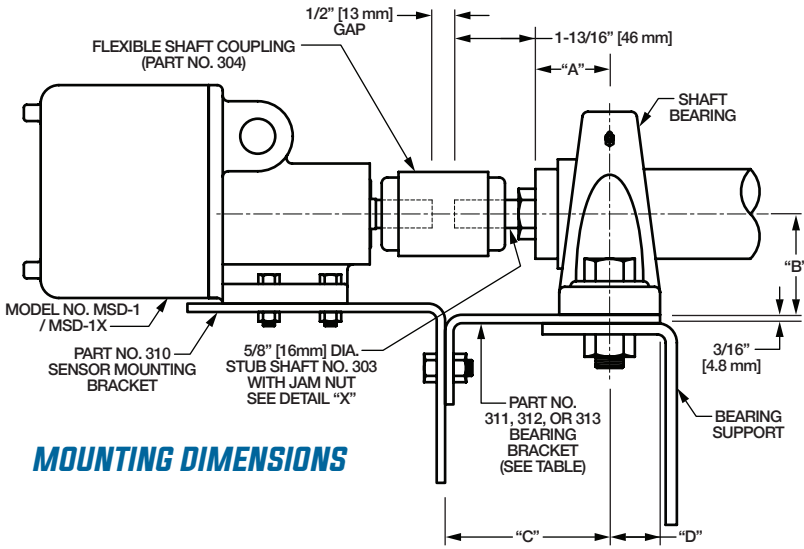

MOUNTING DIMENSIONS

DRILL & TAP FOR 5/8"-11 N.C. THREAD - RIGHT HAND - TAP 1-3/8" DEEP - USE 17/32" DIA. DRILL 1-3/4 DEEP (MIN.)

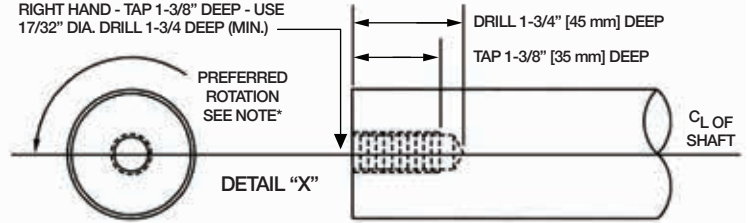

*NOTE: When threaded stub shaft (Part 303 or equal) is to be used, it is recommended that the location of the stub be in the end of the shaft that rotates counterclockwise. This allows the threads to continue being under a constant fastening torque while the shaft turns. If the rotation is clockwise or the shaft is for reversing type service, make sure the jam nut is locked tight against the shaft.

Part No. 310 will fit parts No's. 311, 312 or 313

Bearing Bracket & Shim Plate	All Dimensions Are In Inches				
	Shaft Diameter	"A"	"B"	"C"	"D"
311	1 ¹ / ₁₆	1 ¹ / ₄ to 2	1 ¹ / ₈ to 2 ¹ / ₈	3 ¹ / ₈	1 ¹ / ₈
312	1 ¹⁵ / ₁₆ to 2 ¹ / ₁₆	1 ¹ / ₂ to 2 ³ / ₁₆	2 ¹ / ₄ to 3	3 ³ / ₄	1 ⁵ / ₈
313	2 ¹⁵ / ₁₆ to 3 ¹⁵ / ₁₆	3 to 3 ³ / ₄	3 ¹ / ₈ to 4 ¹ / ₈	4 ¹ / ₂	2 ³ / ₁₆

BEARING BRACKETS AND SHIM PLATES FOR CMS

ACCESSORIES FOR THE MODEL CMS (CMS-DSPO & MSD)



303 STUB SHAFT 5/8" dia., threaded one end, keyed other end. With jam nut and 3/16" key.

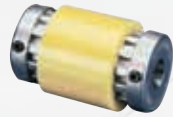

304 FLEXIBLE COUPLINGS Available for connection of the CMS sensor to the driven shaft.



305 COUPLING GUARD
Protection cover for coupling connection.



310 MOUNTING BRACKET
For mounting CMS sensor to rotary machinery.

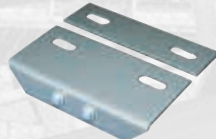

311, 312, 313 BEARING BRACKETS
Attaches 310 mounting bracket to pillow block bearing assembly.

MOUNTING

The control can be mounted in any position, but the mounting surface should be flat and smooth. The bearing brackets and shim plates shown in the chart can be used to mount the unit directly to the pillow block supporting a shaft. Normally, only 1/4" mounting bolts and lock washers are required. If vibration is extreme two of the mounting holes should be doweled and bolts used in the others.

The shaft of the device should be mounted in line with or parallel to the driving shaft. Model CMS can be driven by a flexible coupling, V-belt drive, chain drive, or gear drive.

MODEL CMS DSPO

COMPACT MOTION SWITCH
DUAL SETPOINT & PULSE OUTPUT



The model CMS-DSPO motion sensing control is a compact unit designed to include all mechanical and electronic components into a single housing. It will produce a switching output signal at each of two predetermined speeds; which may be two over-speed, two under-speed or one each over-speed and under-speed. It also produces a pulse rate signal for external monitoring with a PLC or Tachometer.

Add "-DSPO" to end of model number.

MECHANICAL SPECIFICATIONS

RADIAL LOAD ON INPUT SHAFT: 125 lb. max.

END THRUST ON INPUT SHAFT: 100 lb. max.

ROTATION: Either clockwise or counterclockwise

DRIVING TORQUE: 1 inch-pound maximum

SHAFT: 5/8" diameter with 3/16" x 1" square key

ENCLOSURE: Aluminum with screw on cover

MEETS: CMS-1G-DSPO: NEMA Types 3S, 4 & 4X
CMS-1X-DSPO: NEMA Type 7: Class I Groups C & D
NEMA Type 9: Class II Groups F & G (120 VAC units cULus Certified)

Epoxy coating option: add "E" to end of model number.

BEARINGS: (2) Ball Bearings, permanently lubricated and sealed for life

SHAFT SEAL: Leather type oil seal

WEIGHT: 6 lb.

SIZE: 5" high x 5" wide x 8 1/2" long

ELECTRICAL SPECIFICATIONS

INPUT VOLTAGE: 105-135 volts AC, 50/60 Hz.
210-250 volts AC, 50/60 Hz. (Special Order)
24 volts AC/DC, 50/60 Hz. (Special Order)

OUTPUT (RELAYS):

DPDT relay to 3 Amp. Resistive at 120 volts AC
DPDT relay to 3 Amp. Resistive at 240 volts AC
DPDT relay to 3 Amp. Resistive at 30 volts DC
1/10 Horsepower at 120 volts AC
1/10 Horsepower at 240 volts AC

OUTPUT (PULSE):

12V DC NPN; 12 pulses per rev. with standard disk
50 pulses per rev. with optional low-speed disk

AMBIENT TEMPERATURE:

14°F to +131°F (-10°C to 55°C)

MAX. OPERATING TEMP. (CMS-X-DSPO):

Class T6: 185°F (85°C)

REPEATABILITY: +2% maximum at constant voltage and temperature.

POWER CONSUMPTION: 3 Watts